

Tilt-Up Block

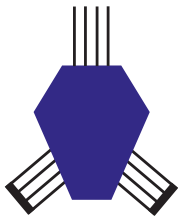

ROPEBLOCK

Date _____

Quote # _____

1. Tonage _____

4. Swivel Shackle Dia. _____

2. Rope Size _____

5. Upset Eye Dia. _____

3. Sheave Dia. _____

Swivel Eye Dia. _____

Swivel Eye w/Shackle Dia. _____

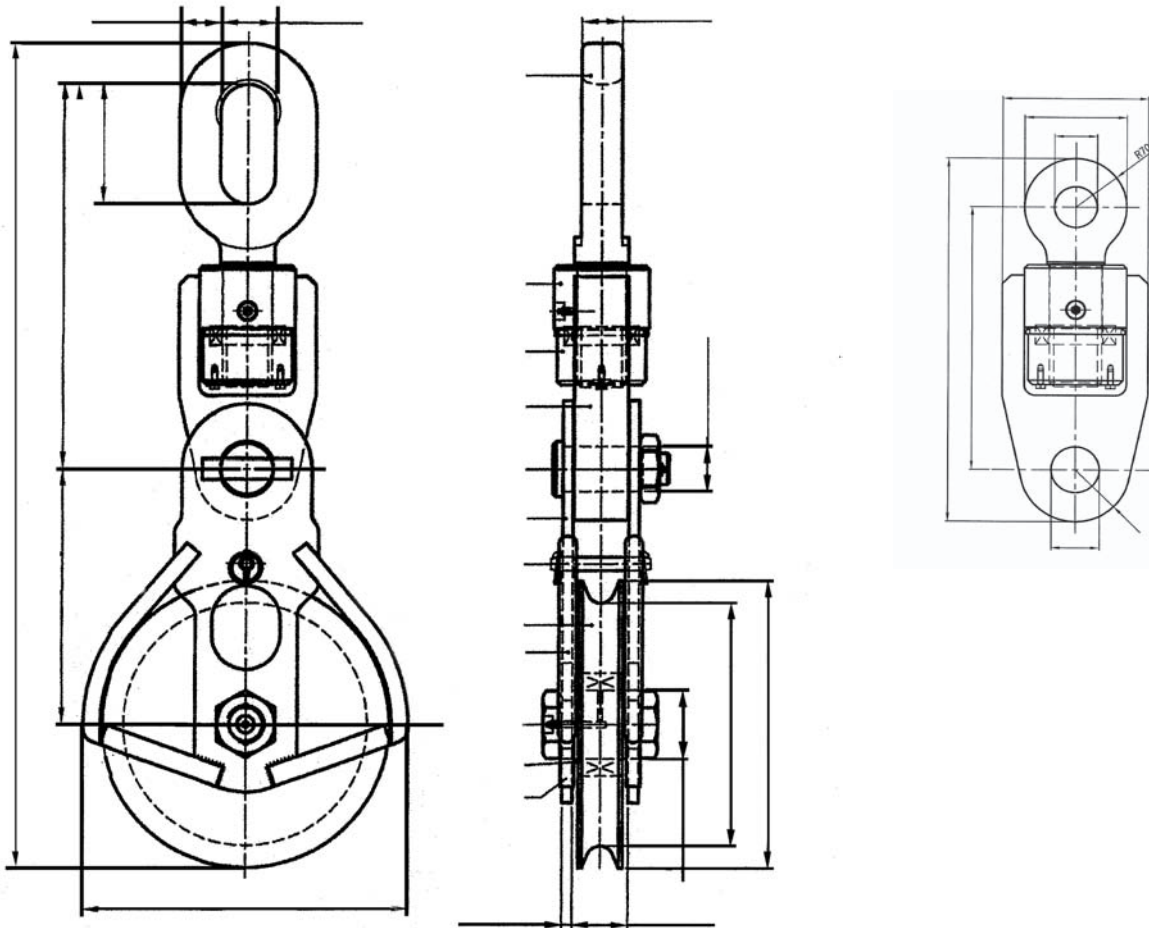

2339 NORTH 34TH DRIVE
PHOENIX, ARIZONA 85009
(602) 269-7878 • FAX (602) 278-5075
Email: azwire@aol.com
www.azwirerope.com

Customer _____

Address _____

Contact _____

Phone _____

Cell _____

Fax _____

Email _____